



WATER AND AIR UV STERILIZERS

**WATER STERILIZERS
MODELS: V20;V20LA;V40;V80;V120**



MANUAL

Patent nr A61L2/10, AA61L9/20

USER SAFETY



Warning !!!

This device may only be operated and installed by qualified personnel. Before installation, servicing or repairs verify the qualifications of personnel and limit these activities to such personnel. Any activities on this device can only proceed after thorough familiarization with this instruction. Noncompliance with the precautions listed hereon might expose personnel to serious bodily harm (damage to human skin from UV radiation), or damage to the device alone. The manufacturer, TMA, is not responsible for damage to the device caused by improper installation, maintenance and operation.

1. READ THE MANUAL.

Before proceeding with any activity with the sterilizers read the manual.

2. RETAIN THE MANUAL.

Retain the manual for reference during the whole time the device is in operation. All precautions and warnings shall be obeyed by the user all times during the operation of the device.

3. POWER SUPPLY AND GROUNDING.

Device is exclusively designed to be supplied from 220-230V 50Hz mains. It shall be installed and grounded in accordance with this manual and the local electrical code.

To guard against electrical shock, unplug the device every time work is to be done on it.

4. GROUNDING.

Operation of the device without connected grounding is inadmissible. Ungrounded operation might lead to occurrence of electrical shock and serious bodily harm with death included. The chamber is grounded with green-yellow wire with an eyelet, which is to be attached with M5 screw to one of the legs on the body of the sterilizer.

5. ULTRAVIOLET RADIATION.

Direct exposure to UV radiation is harmful to human skin and sight, which can cause from reddening of skin to serious burns or ultimately loss of eyesight, depending on the time of exposure. In such cases one shall contact physician as soon as possible. Avoid any exposure to UV radiation.

Instalation and operation instructions

Thank you and congratulations on your purchase of TMA manufactured UV sterilization product. Sterilizers made by TMA are made from highest quality stainless steel. The thickness of the chamber wall guarantees high factor of safety in operation. All the raw materials and components are of best quality and were processes or manufactured in the countries of the EU.

Plastics used in production of the muffs (models V20-V80) withstand 110°C working temperatures. Devices completed successfully 30 Atm pressure trials.

In the models V20-V120 we introduced additional guides for the quartz sleeves easing the assembly and disassembly. This solution allows the same ease of assembly for device working horizontally, vertically or at any angle. This guide prevents the quartz sleeve from breaking during the routine maintenance. The turbulent flow induced by the guide increases the efficacy of disinfection.

During the first 100 hours of operation the efficacy of disinfection is greater by 15% from the rated for the device.

New features allow continuing disinfection even without flow of water thru the chamber. The design of the chamber contributes to lower incidence of sediment from calcium and magnesium on the surface of the quartz sleeve.

Models V40-V80 are equipped with more durable lamps – up to 9 000 hours of service, and model V120 is equipped with amalgamate UV lamp – up to 12 000 hours of service.

Models V20-V80 have a semi-transparent muff having secondary function of a sight glass.

Model V120 is equipped with plastic lamp hood working also as sight glass. This innovative solution of the use of transparent to visible light muff allows optical indication of the state of lamp.

We hold high hopes that the implementations of these innovative solutions fulfill your expectations for new and more efficient products from TMA.

1. Introduction

The device delivered to you is disassembled and shall be protected from sever shocks and drops, as the quartz sleeve and lamps are brittle and fragile. Do not touch lamp glass with bare hands! Fingerprints might cause the glass to break when it is under high operating temperatures. The sterilizer shall be exclusively transported in horizontal position. The manufacturer is not responsible for damage arising from the conditions of transport. Before installation and operation one shall read the instructions and implement the precautions listed.

Noncompliance with these precautions is grounds for releasing the manufacturer from warranty obligations.

2. Applications

- Disinfection with UV radiation is a reliable, simple and inexpensive method of sterilization.
- The use of this method is warranted every time when endangerment from microbes exists.
- Following applications might be listed among many others:
- Potable water in private and municipal installations
- Water potable and process in the restaurant and hotel business
- Process water in the production of medicines and cosmetics
- Water used in processing foodstuff
- Water in beverage production
- Water in swimming pools and fountains
- Control of green algae in ponds.

Sterilizer uses special low pressure UV lamp to produce UV radiation of wavelength of 254 nm which causes **photochemical reaction damaging DNA of microorganisms leading to death or sterility**. Our models, if used as rated, deliver dosage of 400J/m²/recommended dosage 300J/m²/. Water flowing from the sterilizator is ready for immediate use.

Sterilization UV does not change the chemical makeup of water

There is no danger of overdosing either.

3. Technical Specifications

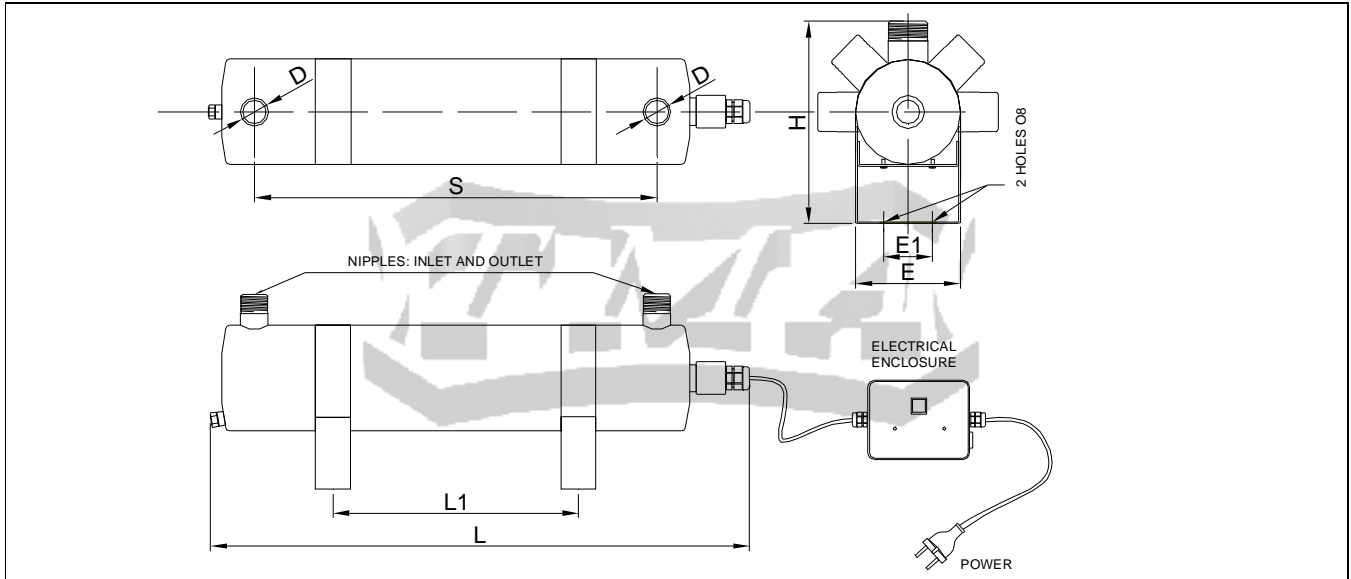

Technical Specifications :

Model	V20	V20LA	V40	V80	V120
Power Supply	220V-230V				
Chamber Material	Stainless Steel				
Finish	Mirror Finish				
Dimensions /length. x width x height./mm	655x130x235mm		955x130x245mm	955x130x245mm	930x130x245mm
Connection Size/Separation Dist	DN25 (R 1")/498mm		DN40 (R 1 1/2")/787mm	DN40 (R 1 1/2")/787mm	DN50(R 2")/530mm
UV Lamps /Number x Nominal Power/	1x 25W		1x 40W	1x 80W	1x 130W
Life of UV Lamps	about 8000 h		about 9000 h	about 9000 h	about 12000 h
Operating Temperature	5-45 °C				0,5-50 °C
Operating Pressure	10bar(1MPa)				
Power UV @y 254nm	7,2W		15,0 W	25,0W	52,0W
Nominal Power	33W		50W	90W	160W
Nominal Flow @ transmittance T ₁₀ =95%,dose 300J/m ²	2,10m ³ /h		4,80m ³ /h	7,80m ³ /h	16,4m ³ /h
Nominal Flow @ transmittance T ₁₀ =95%,dose 400J/m ²	1,60m ³ /h		3,60m ³ /h	5,90m ³ /h	12,3m ³ /h
Sight glass Muff	Yes		Yes t	Yes	Yes
Drain Plug	Yes		Yes	Yes	Yes
Working Orientation	From Horizontal to Vertical				
Electrical Enclosure and Controls					
Material	Plastic				
Safety Class	IP 55				
Dimensions /mm	160x120x70	325x250x120	325x250x120	325x250x120	325x250x120
Audible UV Lamp Fault Alarm	No	Yes	Yes	Yes	Yes
Optical UV Lamp Fault Indicator	Yes	Yes	Yes	Yes	Yes
Optical Power Indicator	Yes	Yes	Yes	Yes	Yes
Working Hours Counter	No	Yes	Yes	Yes	Yes
Solenoid Cut-Off Valve Terminals	No	Yes	Yes	Yes	Yes
Terminals for Remote Alarm Indicator	No	Yes	Yes	Yes	Yes
Mains fuse rating	1A	1A	1A	1A	2A
Weight with Enclosure	8,0kg		10,0kg	11,0kg	12,0kg
UV Intensity Measurement System	By Order /Optional				

Increased flow through the sterilizer lowers the dosage delivered to microorganisms and lowers efficacy of disinfection without the need for bypass installation.

Standard Features

- electrical enclosure,
- lamp working hours counter/**Not included with V20/**,
- audible and optical alarm / **Not included with V20/**
- terminals for remote ON/OFF switch / **Not included with V20/**
- terminals for connecting electromagnetic valve shutting off flow in case of power or lamp failure / **Not included with V20/**

Optional Accessories:

- UV intensity sensor.

4. Description

Sterilizer's chamber is made from stainless steel AISI 304(AISI 316- on special order). The power supply, lamp ballast and control circuit are mounted in electrical enclosure conforming to safety class IP55. The lamp is mounted inside the chamber in quartz sleeve and connected with the enclosure by hi-potential wire. The enclosure houses besides the power supply, the lamp working hours counter, the audible alarm and indicating lights with the terminals for electromagnetic shutoff valve in case of lamp or power failure. / **Not included with V20/**.

To the terminals number 1 and 2 /neutral/ inside the enclosure connect solenoid valve type NZ (open on power on) max.2A.

To the terminals 3 and 4 /life 230V/ inside the enclosure, after removing the jumper cable, connect remote switching on/off of the sterilizer:

1. Closed circuit – sterilizer on
2. Open circuit – sterilizer off.

Power supply specifications 220-230V + 8%, -10%, 50-60 Hz.

Electric shock protection by earth terminal.

Transparent lamp hood or semi-transparent muff allows for indication of working condition of the lamp.

5. Instructions for Installation and operation /pic 1,2/

- 1) Device can be mounted in either horizontal or vertical position. Temperature range for installation is from 5 to 45°C.
- 2) Upstream of the intake install potable water filter. Minimum rating 0.1 mm recommended 0.05 mm
- 3) Install manual cut-off valves, upstream of intake and downstream of outlet. /pic. 1/
- 4) Electrical enclosure /pic 8/mount on wall 120 cm from the floor.
- 5) Place the quartz sleeve into the chamber pic.4, p.1/.
- 6) Place the o-ring over quartz sleeve and into the lip of the nipple. Next place the washer over the o-ring, screw the muff onto this assembly. Turn the muff to considerable resistance in order to tighten the seal. Tightening the muff shall not break the sleeve. /pic.4, p.2, pic.5, p.3,4/.
- 7) Fill the chamber under full pressure and check the seal.
- 8) Place the lamp UV /pic.6/ in the sleeve /pic.7/.
- 9) Plug the unit into **grounded** outlet 220-230V, 50 Hz.
- 10) Power the unit by turning switch on the side of the electrical enclosure – green indicator light shall turn on.
- 11) Replace the lamp after work time of 8 000 hours for V20, 9 000 hours for V40-V80 and 12 000 hours for V120.

Any fault of the device or burnout of the lamp shall cause the red indicator light and the audible alarm to turn on.

ATTENTION!

In the case of installation of the electromagnetic shutoff valve upstream /downstream/ of sterilizator (terminals number 1 and 2) in the moment there is a power failure or sterilizator fault automatically the valve will close and flow thru the chamber will stop, as /pic.1a/. There is no continuity between the terminals in case of alarm or power failure. For proper operation of the valve the connections as shown must be made with the mains 220-230V 50Hz.

Electromagnetic shutoff valve use guards against flow of undisinfected water downstream of the installation in the case of power failure, sterilizator fault or lamp burnout

6. Maintenance

- a) Cleaning the quartz sleeve is necessary as the deposit on the sleeve lower the efficacy of disinfection.
- b) **It is recommended to clean the sleeve at least when the lamp is replaced.**
- c) **Inlet and outlet valves shall be opened slowly to prevent the rush of fluid hitting and damaging the quartz sleeve.**
- d) There is no need for minimal flow thru the device.
- e) UV radiation damages skin and eyesight. Avoid exposure.
- f) The UV disinfection does not affect the water quality. Contact your dealer if you need other equipment to soften, deiron and filter water.
- g) In case high turbidity and waste water effluent the efficacy of disinfections are lowered. Contact your dealer or manufacturer for advice.
- h) Avoid frequent turning on and off the equipment. One on-off cycle lowers The UV lamp life by about 10-20 hours.
- i) Flow rate through the device can be increased. This lowers the delivered dosage and lowers the efficacy of disinfection.
- j) The lamp needs about 2 minutes to reach full capacity at temperature of water about 12-16 °C. If the water is at temperature 5-12 °C the time might be about 3-5 minutes.
- k) If the sterilizator is left idle for longer period of time or it can freeze we recommend that the water be drained from the chamber. The chamber is provided with drain plug.
- l) **Bioassay samples shall be collected into sterile opaque containers as not to expose the sample to the light to avoid photo reactivation of microorganisms, which can rebuild their damaged DNA in presence of light.**
- m) **Model V120 is equipped with electronic ballast which can be damaged when operated with a lamp older than 12,000 working hours. The responsibility of timely lamp replacement is with the user.**
- n) Even short lived surge, to above 254V, can damage the electronic ballast driving the UV lamps (Model V120).
- o) The leakage current going into grounding is 1,5 ma for UV lamp electronic ballast (Model V120).

7. Assembly

- a) Quartz sleeve -/pic 4 and pic 5/(check the tightness of seal before assembling the UV lamp)
- b) UV Lamp -/rys 6 i rys 7/
- c) Sufficient is hand tightening the muff. Hand tightening shall not damage the quartz sleeve.

8. Replacement UV lamp - /pic 7/

- a) Unplug unit
- b) Allow for lamp to cool down from operating temperature. No flow through sterilizer necessary.

- c) Loosen the strain relief grip on cable (model V20-V80), or take off lamp hood (model V120)
- d) Remove strain relief from muff (model V20-V80),
- e) Remove lamp from the sleeve
- f) Remove sockets from connectors of the UV Lamp,
- g) Place sockets on new UV lamp connectors – do not touch the lamp with bare hands,
- h) Place the UV lamp in the sleeve
- i) Mount the strain relief back or place the lamp hood.

Attention: Model V120 sterilizer UV lamps must have special centering ring at both ends. When the UV lamps are shipped from the manufacturer the centering rings are provided with every lamp.

9. Replacement and Cleaning of quartz sleeve (fragile and brittle)

- a) In order to replace the quartz sleeve one reverses the actions take during the installation p.7 /Assembly -pic 4 and pic 5/,
- b) Every time the UV lamp is replaced the quartz sleeve shall be cleaned with common glass cleaners and the inside of the sleeve to be thoroughly dried so that no liquid is left there,
- c) At the time of replacement of UV lamp the o-ring shall be replaced as well,**
- d) Place the sleeve in the chamber of the reactor /pic.4,5/,
- e) Hand tighten the muff with the new o-ring /pic. 5 p. 4/, In model V120 use the provided tool.
- f) Open the shutoff valves slowly to pressurize the chamber and watch for leaks at the o-ring,
- g) Place the UV lamp /pic. 7 /.

10. Shipping

Ship sterilizer only in horizontal position. It should be disassembled for shipping. The quartz sleeve and lamp should be packed separately as they are brittle. They should be sufficiently well packed to withstand rough handling.

11. Warrantee

Manufacturer grants warrantee for the period of 60 months from the date of sale on the chamber made from stainless steel.

Power supply and control circuitry is on 24 months warrantee.

Faulty equipment are to be returned to the dealer.

No repair of the power supply and control circuitry shall be done by user.

Warranty does not cover the UV Lamps and quartz sleeve.

The manufacturer can not held be liable for any damages arising from use or failure of the equipment.

The warranty covers only replacement or repair of faulty parts or equipment.

DEVICES OR PARTS NOT BEARING THE TMA LOGO ARE NOT COVERED BY WARRANTY.

A. LEGENG FOR INDICATOR LIGHTS ON ENCLOSURE

Lighted color indicator lights inform operator of status of sterilizer. Certain conditions can be identified from the configuration of lights. For these corrective action are listed below:

Alarm Red Light	System Light Green Light	Problem	Action
OFF	ON	No fault	-
OFF	OFF	No power connected. Model V120 – tripped circuit breaker	Check power. Model V120 – reset circuit breaker.
ON	ON	1.Old or faulty UV lamp 2.Faulty starter	1.Replace UV lamp 2.Replace starter

B. TROUBLESHOOTING

Problem	Cause	Action
Burnout UV Lamp Water inside quartz sleeve.	Muff not tightened sufficiently. Worn out o-ring	Take quartz sleeve out, dry interior, change o-ring, and assemble back. Tighten muff.
Model V120 – Burn out UV Lamp Water inside quartz sleeve - . short circuit – open circuit on circuit breaker	Muff not tightened sufficiently. Worn out o-ring	Take quartz sleeve out, dry interior, change o-ring, and assemble back. Tighten muff. If UV lamp does not work – electronic ballast damaged – replace – contact dealer
UV lamp goes off	End of life of lamp caused by number of working hours and number on-off cycles.	Replace UV lamp.



ULTRAVIOLET WATER STERILIZER V20-V120

DWG #

TITLE

CONNECTINS FOR SOLENOID VALVE

1A

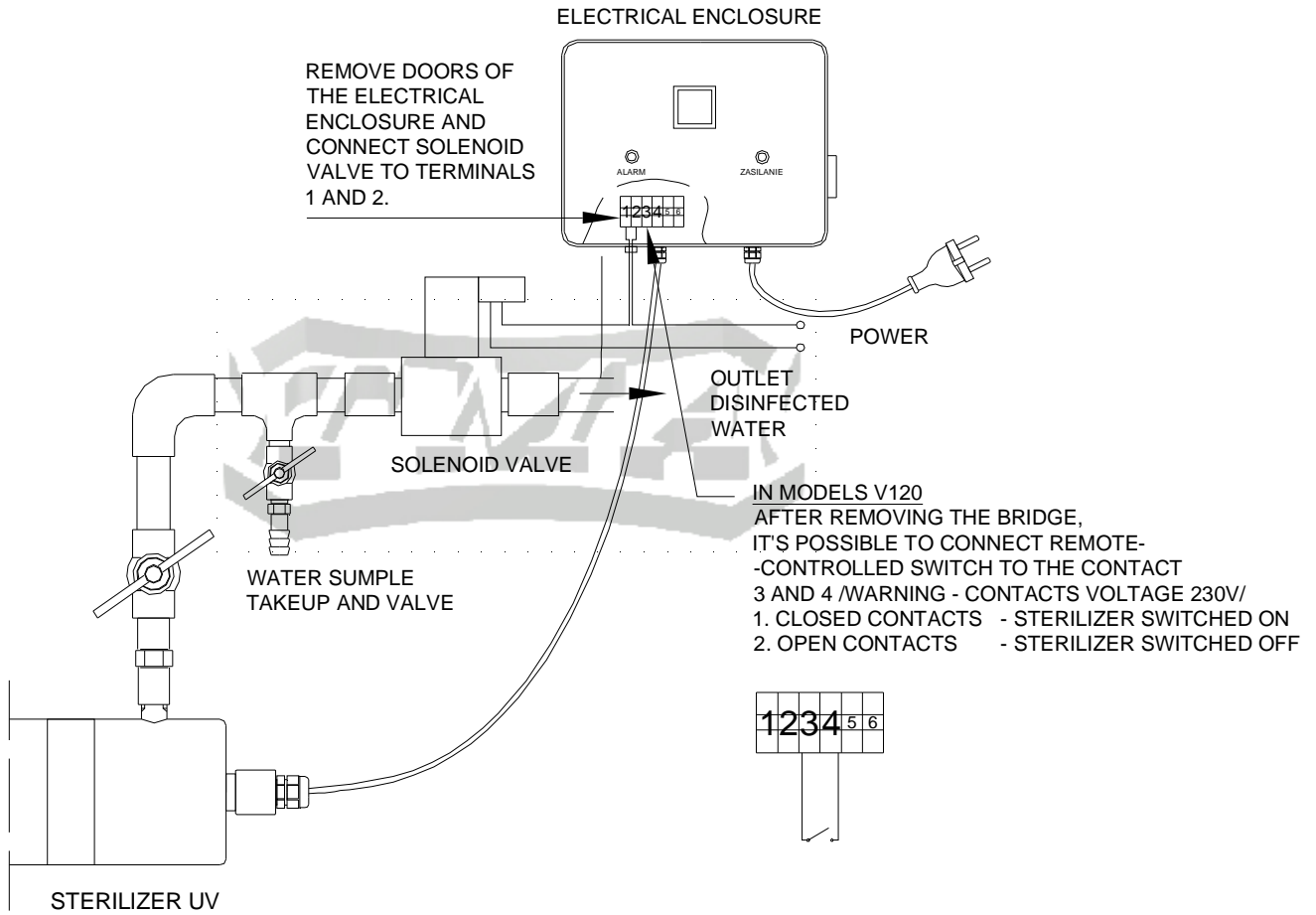



ULTRAVIOLET WATER STERILIZER V20-V80

DWG #

TITLE

MOUNTING ARRANGEMENTS

2

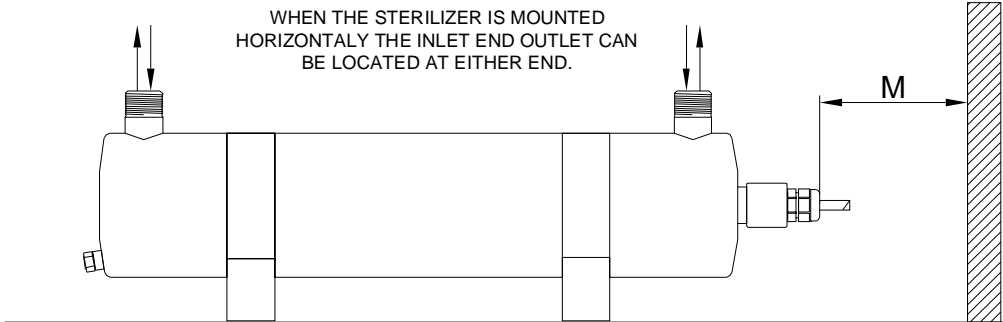

WHEN THE STERILIZER IS MOUNTED HORIZONTALLY THE INLET END OUTLET CAN BE LOCATED AT EITHER END.

1. LOOSEN THE SCREW AND ADJUST THE POSITION OF THE CHAMBER FOR THE INSTALLATION NEEDS.
2. TIGHTEN THE SCREWS.

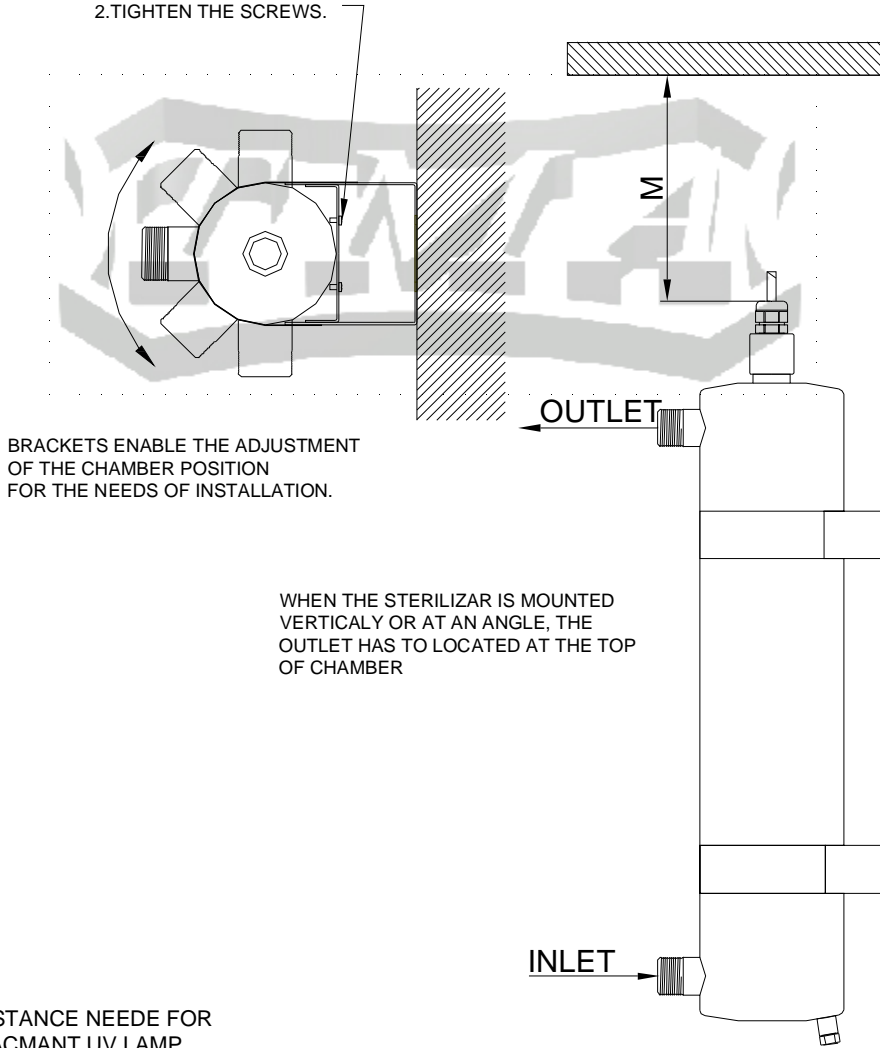

BRACKETS ENABLE THE ADJUSTMENT OF THE CHAMBER POSITION FOR THE NEEDS OF INSTALLATION.

WHEN THE STERILIZER IS MOUNTED VERTICALLY OR AT AN ANGLE, THE OUTLET HAS TO LOCATED AT THE TOP OF CHAMBER

M - DISTANCE NEEDED FOR REPLACEMENT UV LAMP

	ULTRAVIOLET WATER STERILIZER V20-V80		DWG #
	TITLE	OVERALL DIMENSIONS	3

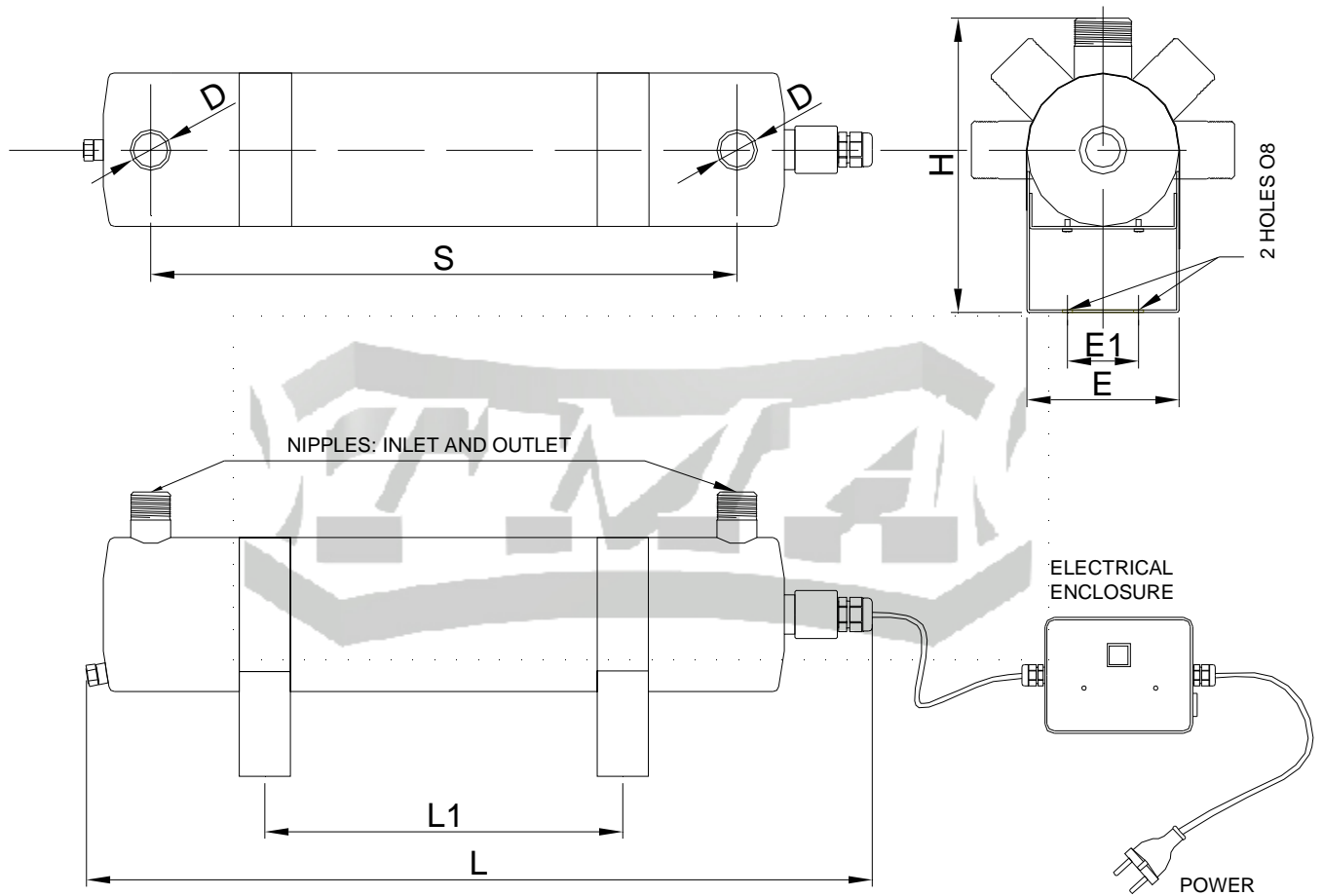

TYPE	V20, V20LA	V40	V80	V120
L/mm	655	955	955	955
L1/mm	330	530	530	530
S/mm	498	787	787	768
H/mm	240	240	240	240
D	R 1"	R 1 ½"	R 1 ½"	R 2"
E/mm	130	130	130	130
E1/mm	60	60	60	60



ULTRAVIOLET WATER STERILIZER V20-V120

DWG #

TITLE

ASSEMBLY OF QUARTZ SLEEVE

4

1. INSERT THE QUARTZ SLEEVE INTO THE NEST AT THE FAR END OF CHAMBER

IN THE CASE OF HORIZONTAL MOUNTING ARRANGEMENT SLEEVE IS INSERTED IN THE CHAMBER END GUIDED INTO THE NEST.

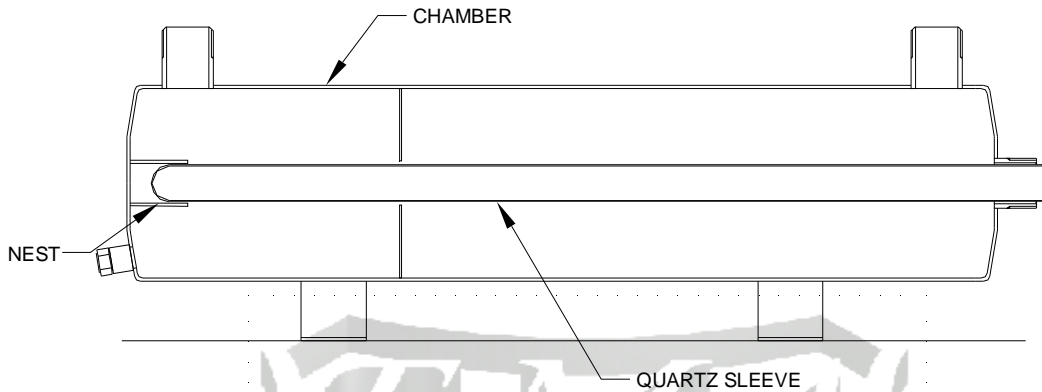

2. PLACE O-RING ON THE QUARTZ SLEEVE.

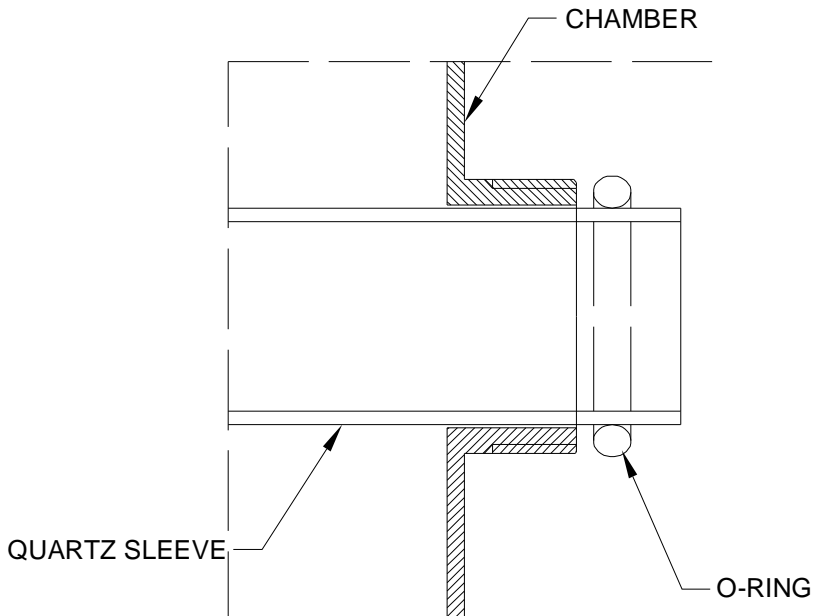



ULTRAVIOLET WATER STERILIZER V20-V120

DWG #

TITLE

V20-V80 -ASSEMBLY OF QUARTZ SLEEVE

5.1

3. PLACE WASHER OVER O-RING AND SCREW-ON THE MUFF.
TORQUE THE MUFF BY HAND AND TIGHTEN TO SET THE O-RING.

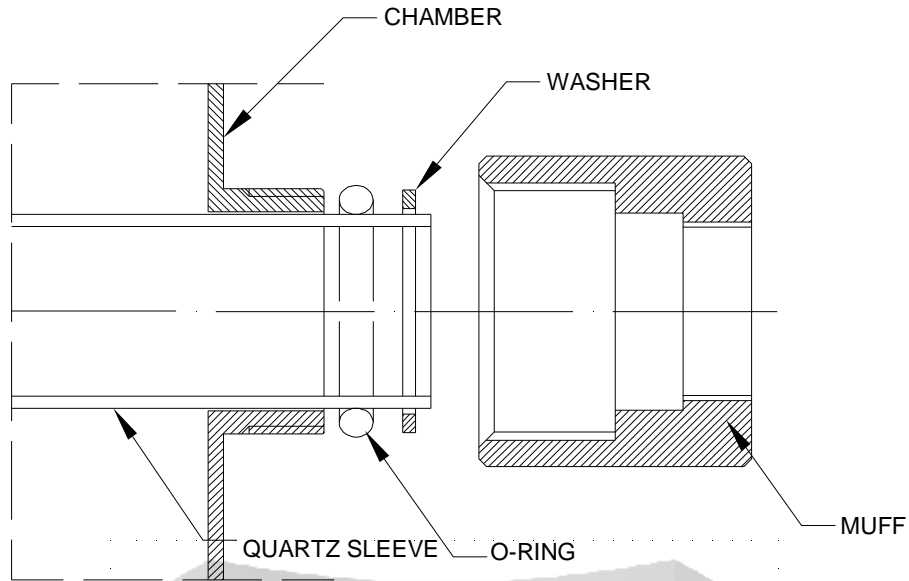

4. GOOD SEAL DEVELOPS WHEN THE SURFACE OF CONTACT BETWEEN O-RING AND THE SLEEVE IS LARGEST. O-RING IS VISIBLE THROUGH THE SLEEVE.

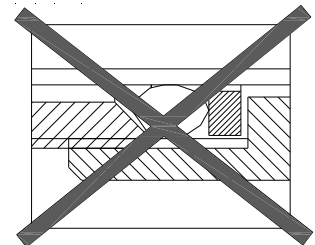
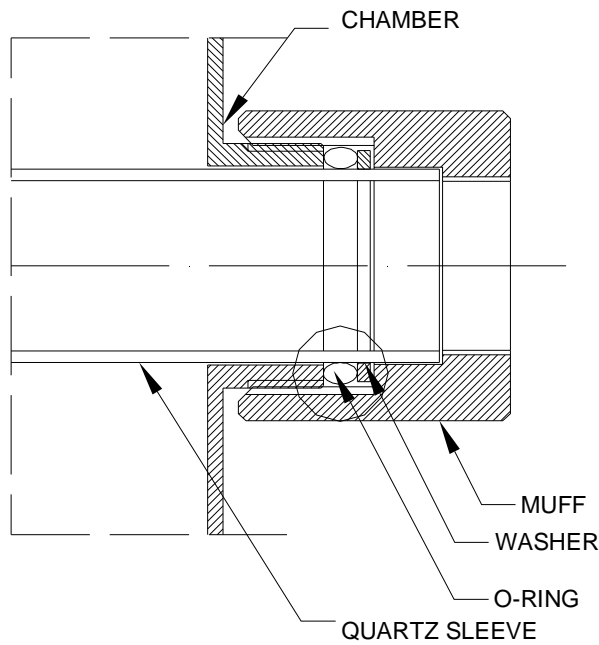

O-RING BEFORE TIGHTENING MUFF
/SMALL SURFACE OF CONTACT/

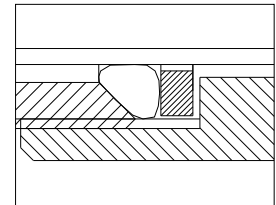

O-RING AFTER TIGHTENING
/LARGE SURFACE OF CONTACT/



ULTRAVIOLET WATER STERILIZER V20-V120

DWG #

TITLE

V120 -ASSEMBLY OF QUARTZ SLEEVE

5.2

3. PLACE WASHER OVER O-RING AND SCREW-ON THE MUFF.
TORQUE THE MUFF BY HAND AND TIGHTEN TO SET THE O-RING.

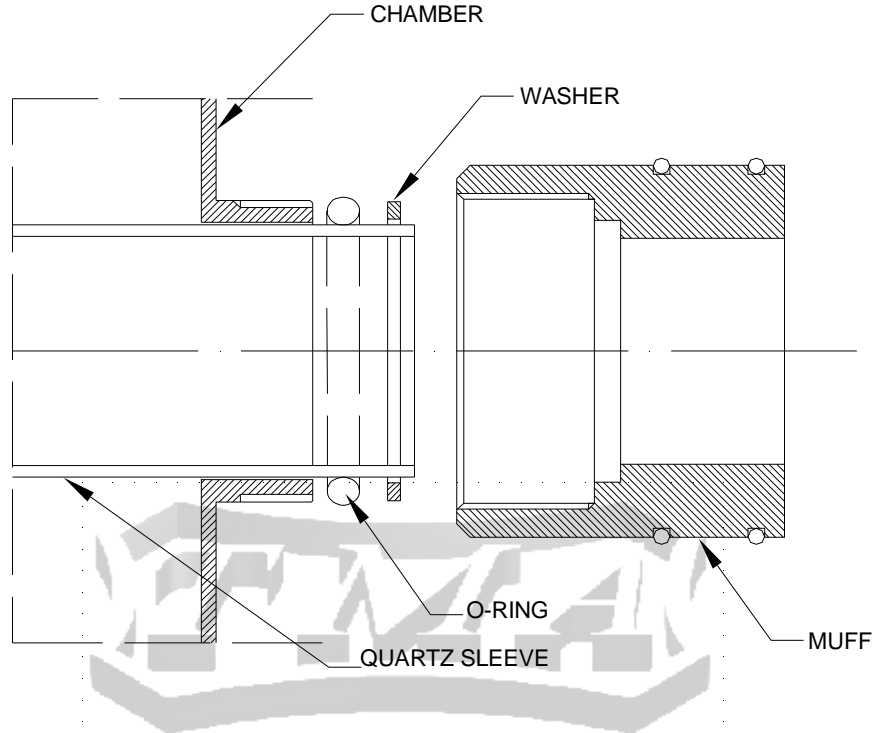

4. GOOD SEAL DEVELOPS WHEN THE SURFACE OF CONTACT BETWEEN O-RING AND THE SLEEVE IS LARGEST. O-RING IS VISIBLE THROUGH THE SLEEVE.

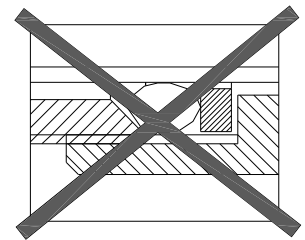
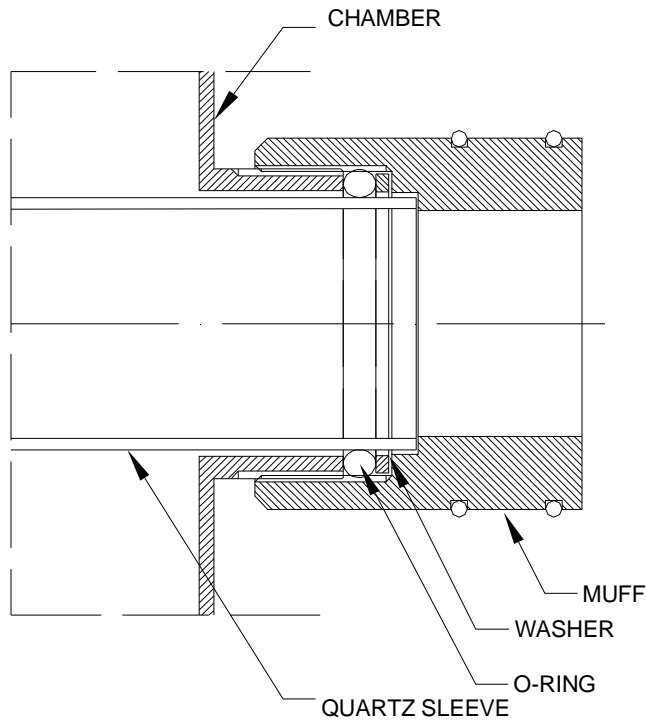

O-RING BEFORE TIGHTENING MUFF
/SMALL SURFACE OF CONTACT/

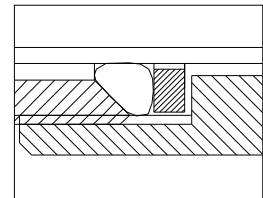

O-RING AFTER TIGHTENING
/LARGE SURFACE OF CONTACT/



ULTRAVIOLET WATER STERILIZER V20-V120

DWG #

TITLE

V20-V80 - ASSEMBLY OF UV LAMP

6.1

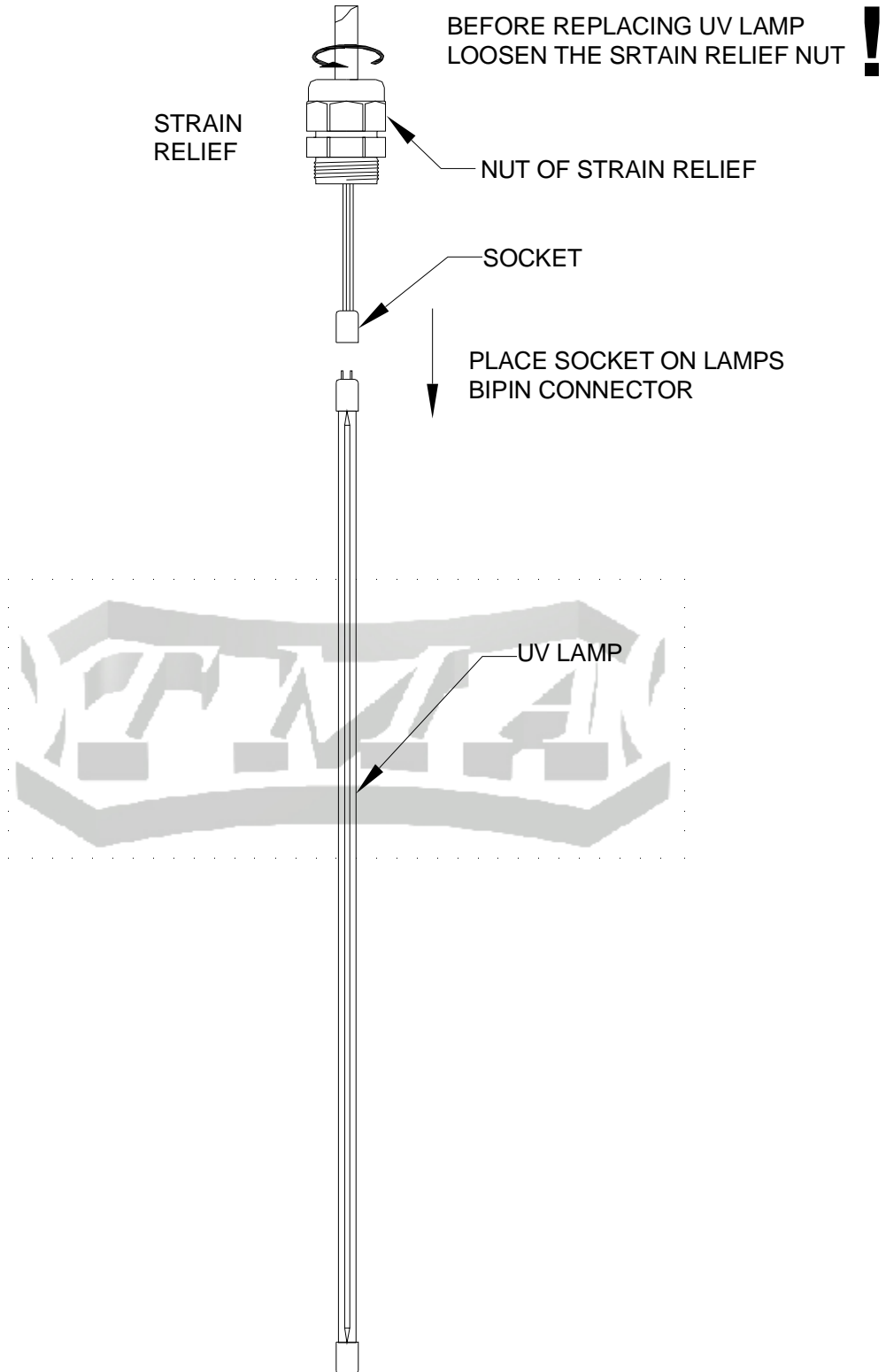



ULTRAVIOLET WATER STERILIZER V20-V120

DWG #

TITLE

V120 - ASSEMBLY OF UV LAMP

6.2

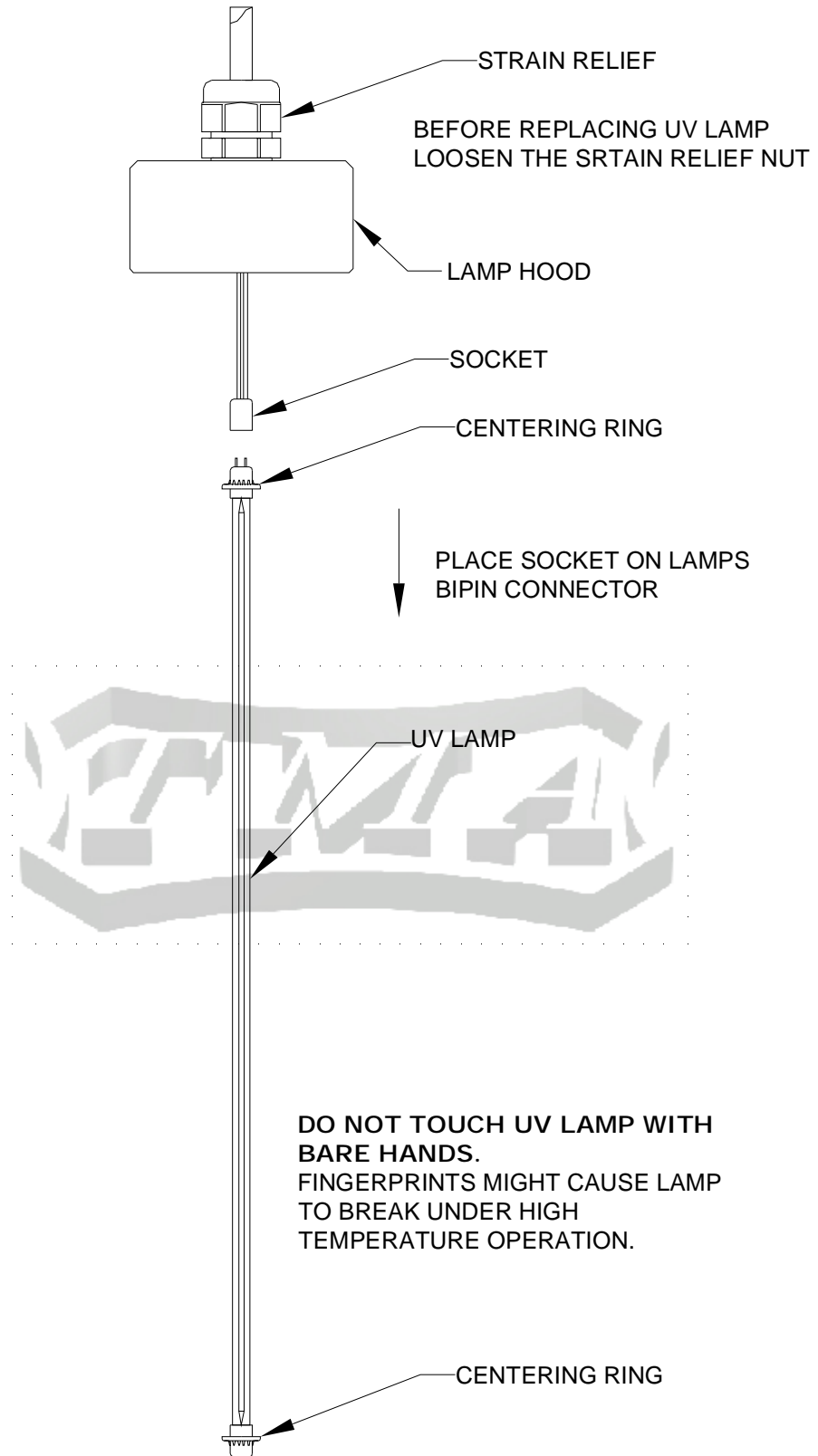



ULTRAVIOLET WATER STERILIZER V20-V120

DWG #

TITLE

V20-V80 - ASSEMBLY OF UV LAMP

7.1

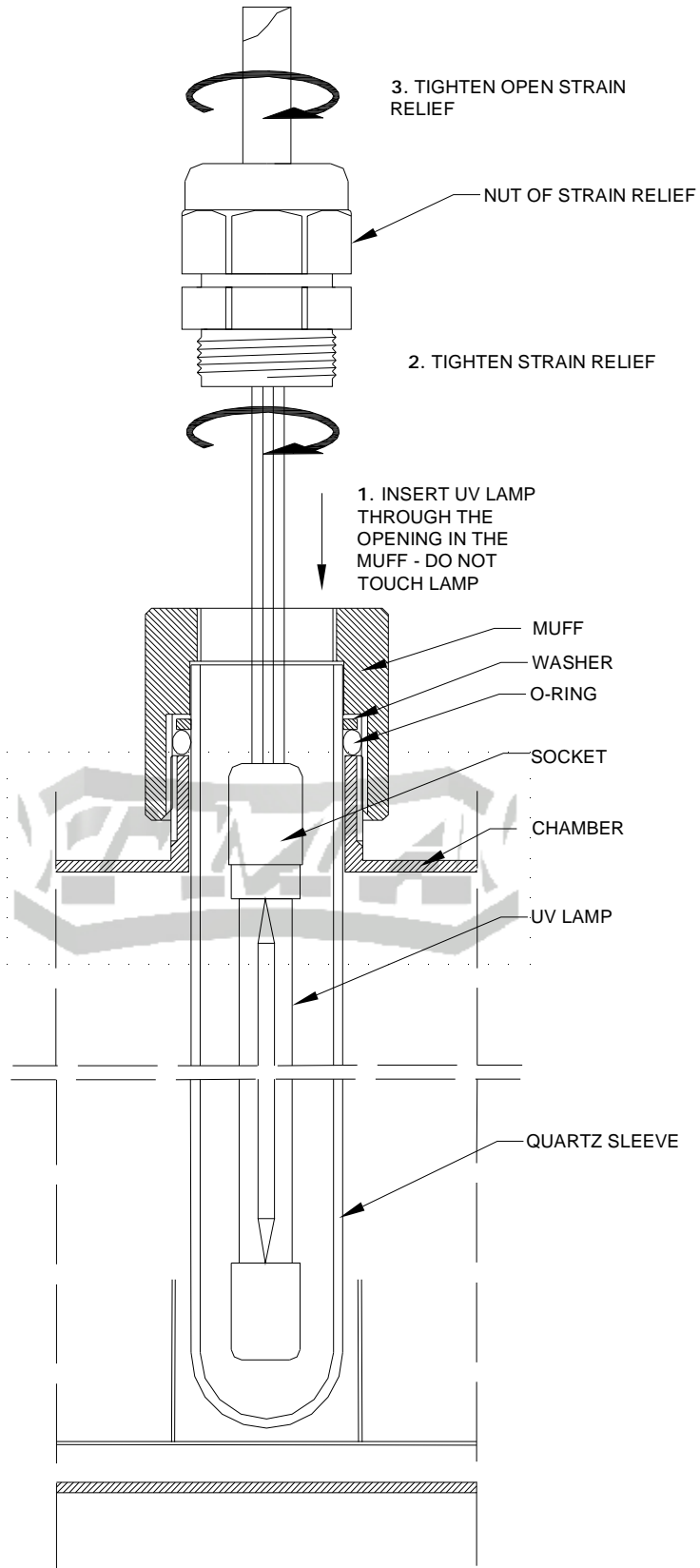



ULTRAVIOLET WATER STERILIZER V20-V120

DWG #

TITLE

V120 - ASSEMBLY OF UV LAMP

7.2

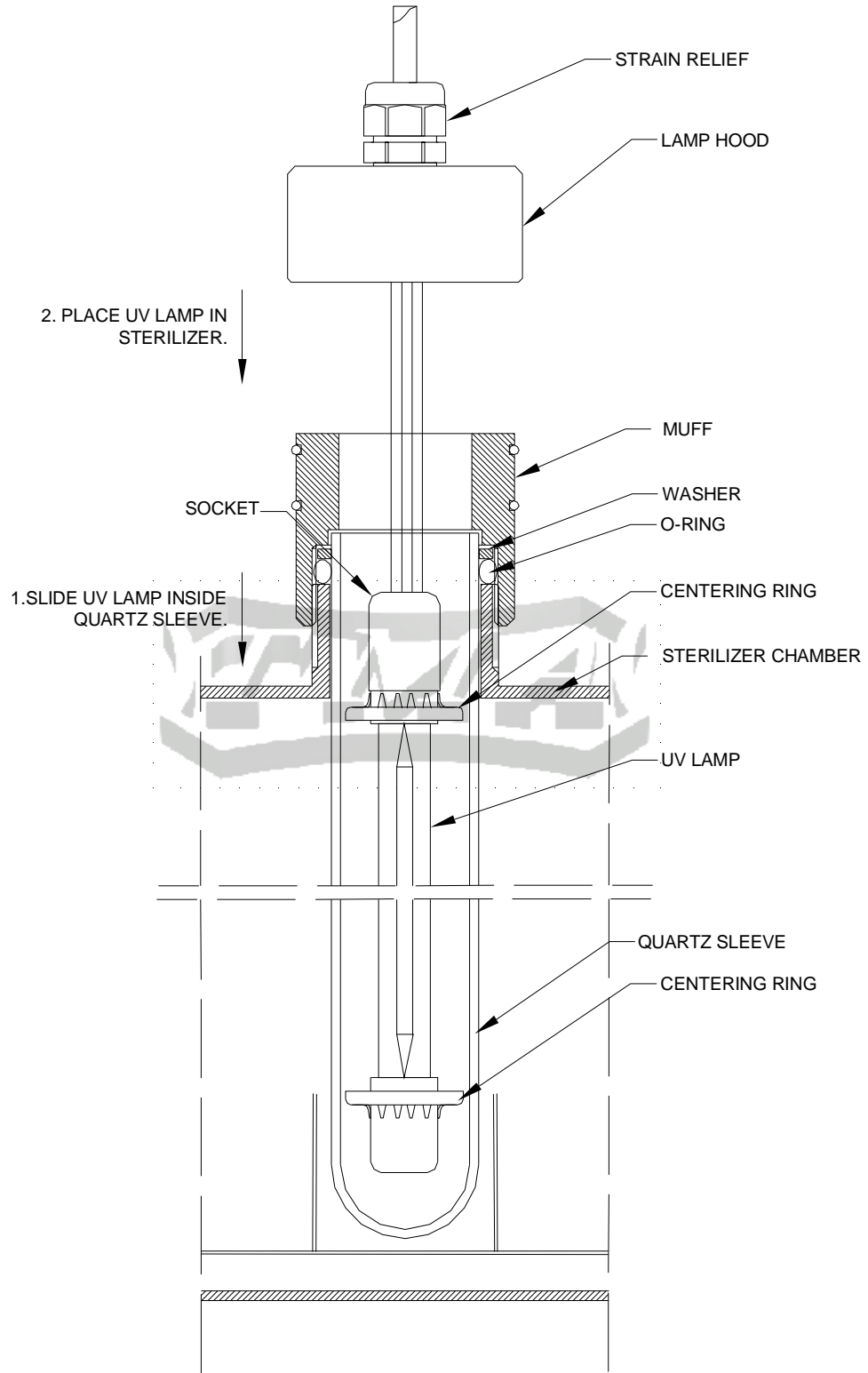

	ULTRAVIOLET WATER STERILIZER V20-V120		DWG #
	TITLE	ELECTRICAL ENCLOSURE	8

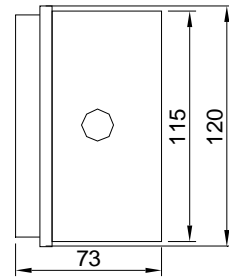
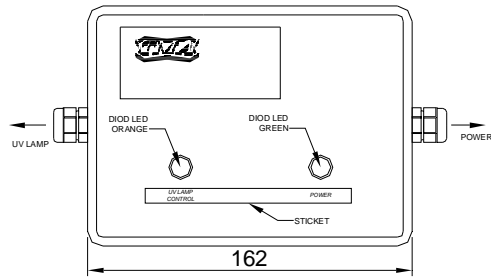

ELECTRICAL ENCLOSURE TO V20

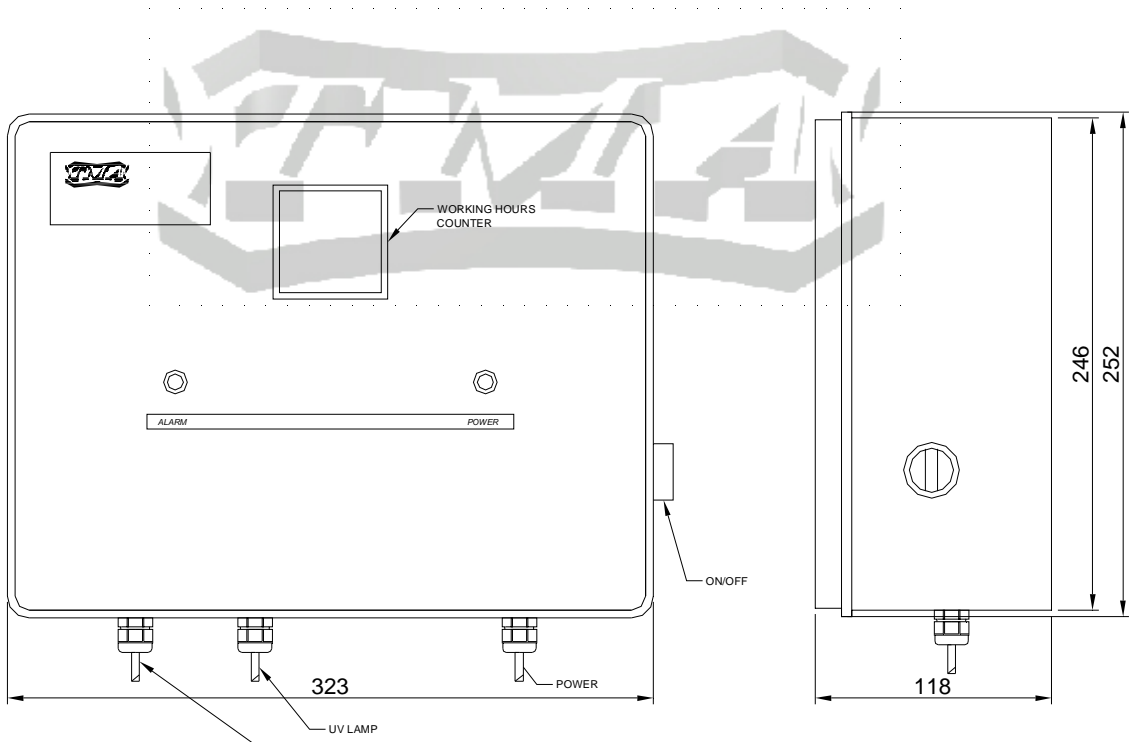

ELECTRICAL ENCLOSURE TO V20L-120

SOLENOID VALVE COCORT / OPEN ON POWER-ON
 TERMINALS 1 & 2 max. 2A/
 2. V120 - REMOTE POWER SWITCH / TERMINALS 3 & 4/
 CIRCUIT CLOSED - POWER SWITCH ON,
 CIRCUIT OPEN - POWER SWITCH OFF.

	ULTRAVIOLET WATER STERILIZER V20-V120		DWG#
	TITLE	V20 – V120 – STERILIZER ORIENTATION DIAGRAM	9

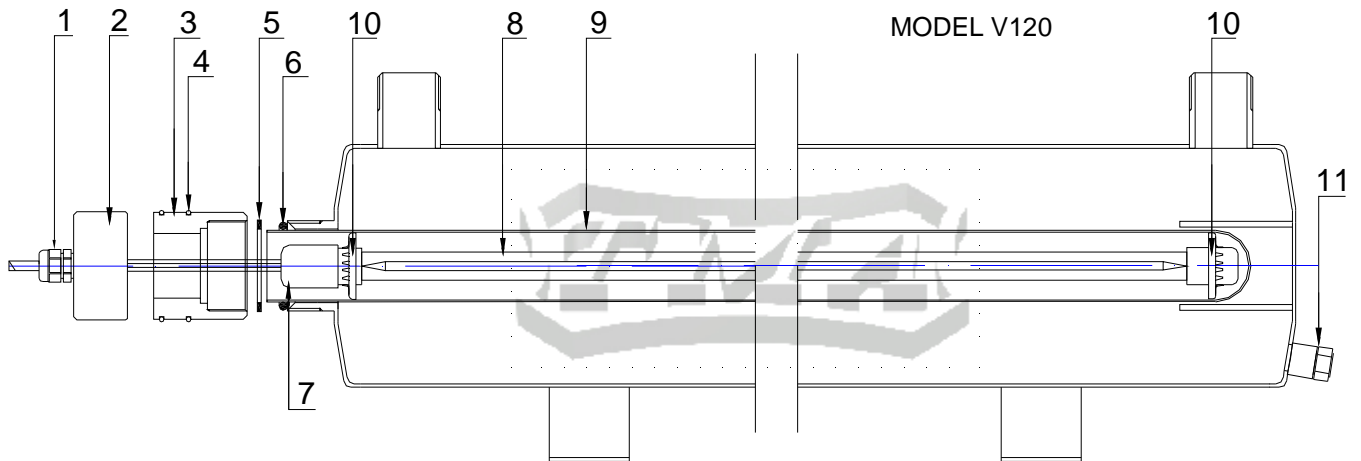
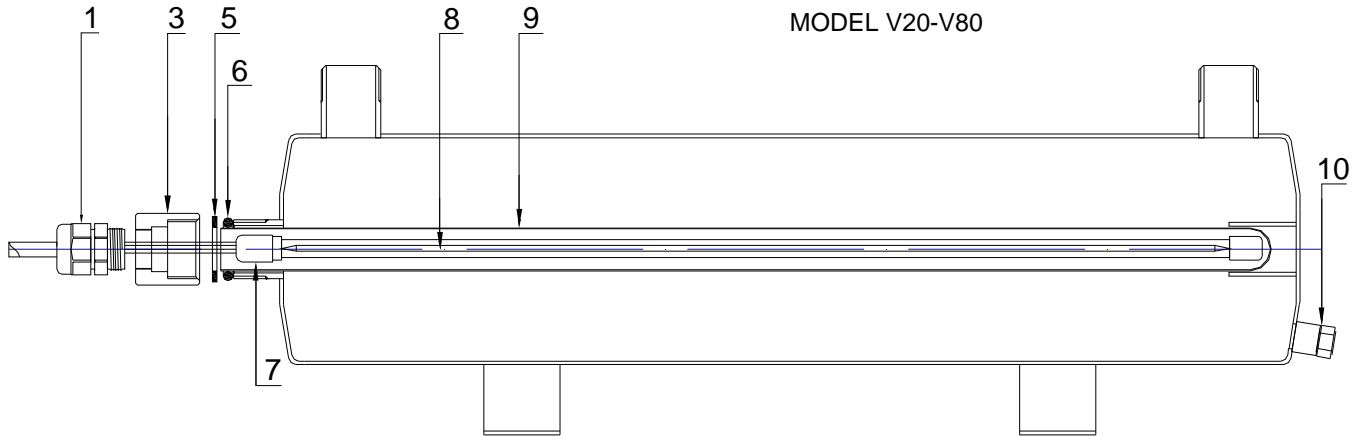

PART		V20		V40		V80		V120	
1	STRAIN RELIEF	02.01	1 pcs	02.01	1 pcs	02.01	1 pcs	01.01	1 pcs
2	LAMP HOOD	-----	-----	-----	-----	-----	-----	01.02.02	1 pcs
3	MUFF	02.04.01	1 pcs	02.04.01	1 pcs	02.04.01	1 pcs	01.04.01	1 pcs
4	O-RING MUFF	-----	-----	-----	-----	-----	-----	01.03.01	2 pcs
5	WASHER	02.05	1 pcs	-----	-----	-----	-----	01.05	1 pcs
6	O-RING	02.06	1 pcs	02.06	1 pcs	02.06	1 pcs	01.06	1 pcs
7	SOCKET	03.08	1 pcs	03.08	1 pcs	03.08	1 pcs	01.08	1 pcs
8	UV LAMP	09.07	1 pcs	10.07	1 pcs	11.07	1 pcs	12.07	1 pcs
9	QUARTZ SLEEVE	09.09	1 pcs	10.09	1 pcs	11.09	1 pcs	12.09	1 pcs
10	CENTERING RING	-----	-----	-----	-----	-----	-----	01.15	2 pcs
11	DRAIN PLUG	01.12	1 pcs	01.12	1 pcs	01.12	1 pcs	01.12	1 pcs